

1.6" square NTS

PARTS LIST	
1	MaxDim Duo w/spade lugs
1	Installation Instructions Optional
4	Color Coded Ring terminals
1	Reference panel label Optional
1	STC Printout for logs Optional
1	Installatin Template Optional
1	Knobs .5" and .75"
2	Allen Wrenches
1	9mm x .75, nut, washer, lock washer

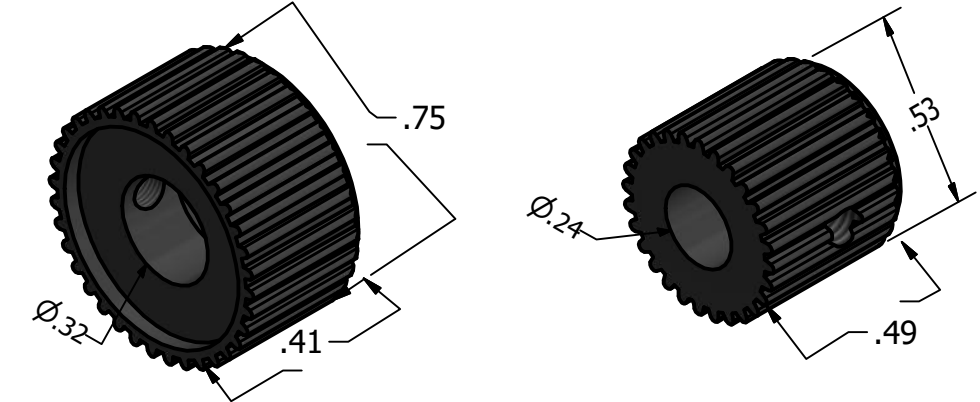
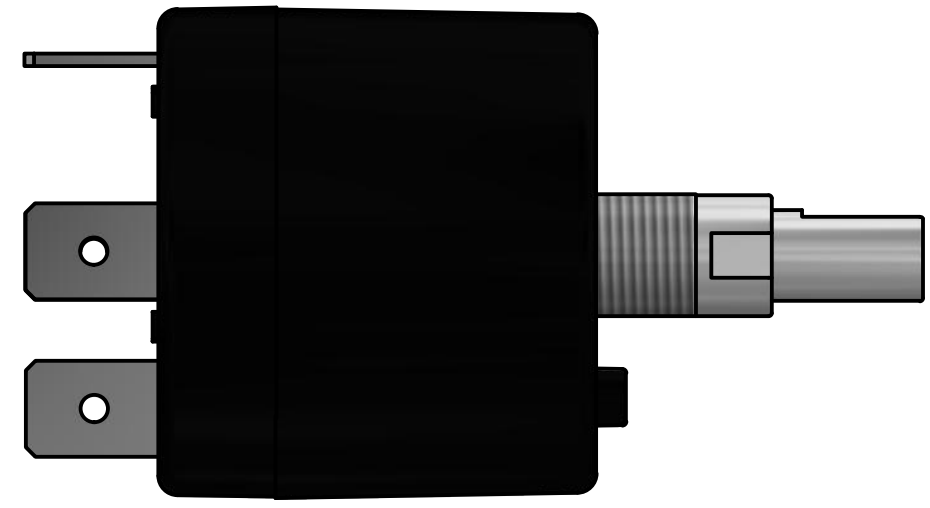

SPECIFICATIONS	
STC/PMA	SA01800SE/PQ2574NM
DO-160E Testing	SEC. 21: RFE (EMI)
Voltage Range	12 to 35 VDC
Maximum Current	10 A per Channel
Output Channels	2
Internal Temp Protected	+85 degrees C
Enclosure Material	Bayer FR110 Resin meets UL94
Weight	1 ounce (28g)
Warranty	One Year Limited
Storage Temperature	-40C to +100C
Operating Temperture	-30C to +85C
Internal Temp	+25 C at 10 A

DIMENSIONAL TOLERANCES		
Fractions	Decimals	Angles
+/- 1/32	.XX +/- .08	+/- 1 degree
	.XXX +/- .010	
	X +/- .1	

REVISION HISTORY				
ZONE	REV	DESCRIPTION	DATE	APPROVED
All	--	Initial	3/3/2013	JB

DRAWN JB 3/3/2013 CHECKED JC 8/6/2013 QA MFG JB 3/2/2013 APPROVED JB 3/2/2013	 Seaton Engineering TITLE MaxDim Duo w/spade terminals SIZE B SCALE 2 : 1	DWG NO 9100-001-C REV -- SHEET 1 OF 1
---	---	--