

# MicroDim Dual P/N 9100-001-J

## Rev SWP (Short Wing Piper)

### PARTS SUPPLIED 9100-001-J:

- 1 ea MicroDim Controller P/N 9100-001-J, Rev. SWP, installation manual
- 4 ea fully insulated blue female #6 crimp-on ring terminals for 14-16 AWG wire
- 4 ea 6-32 X 1/4" button head socket SS screws including #6 SS internal lock washer
- 1 ea 1/16" long handle key Allen wrench
- 1 ea 5/64" long handle key Allen wrench
- 1 ea knob, various mounting hardware, 2 placards

### CAUTION - REVERSE WIRING OF POWER TO DEVICE WILL DAMAGE IT.

### NEW INSTALLATION:

1. Locate a convenient place for the MicroDim Controller. Drill a 9mm hole at the location where the center of the MicroDim is desired. Drill 2mm anti-rotation pin hole if required.
2. Determine the current that the circuit will be required to carry.
3. Test position of the MicroDim Controller and determine if any additional wire is required.
4. Remove the MicroDim Controller and proceed with the installation. From a **WIRE SIZE-CURRENT CAPACITY TABLE**, select the wire size required. If the installation is in an aircraft, use only MIL-W-16878E/4 Type E, Teflon insulated, Silver-Plated Copper Wire or equivalent.
5. Find the location of the power source.
6. Install a breaker of "Calculated Size", see wiring diagram for sizing.
7. Run a wire from the breaker to the MicroDim Controller positive (POS) terminal, then select and crimp a blue female solderless ring terminal to the end of the wire. Attach the ring terminal to the positive terminal on the MicroDim Controller using a washer and a SS screw .
8. Using the same technique that was used in section #7, run a wire from the GND ring terminal on the MicroDim to system ground. The common (GND) wire is simply a signal wire used by the unit. It does not carry heavy currents during operation. Use a blue female solderless ring terminal for this wire.
9. Again using the same technique that was used in section #7, run a wire from the output CKT on the dimming circuit. Select and crimp a blue ring terminal to the end of the wire. Attach the ring connector to the CKT terminal on the MicroDim Controller using a washer and a button head socket SS screw.
10. Having installed the label over the 9mm drilled hole using the label installation instructions, next insert the MicroDim Control from the rear into the drilled hole and install a washer and nut to hold the MicroDim Controller in place and tighten the nut.
11. Install the knob using the long handle key Allen wrench provided.

### EXISTING/REPLACEMENT INSTALLATION:

1. Locate a convenient place for the MicroDim Controller. Drill a 9mm hole at the location where the center of the MicroDim is desired. Determine the positive supply, MicroDim circuit, and negative ground wiring.
2. Test Position the MicroDim and determine if any additional wire is required for the installation.

3. Insure that a breaker for the MicroDim Controller power source is installed in series with power source and sized to "Calculated Value" as defined on the wiring diagram.
4. Remove the MicroDim and proceed with the installation. If additional wire is required, select the correct wire size from the wire size-current capacity table. If the installation is in an aircraft, use only MIL-W-16878E/4 Type E, Teflon insulated, or equivalent Silver-Plated Copper Wire.
5. Run a wire from the breaker to the MicroDim Controller positive (POS) terminal, then select and install a blue female solderless ring terminal to the end of the wire. Attach this to the POS terminal on the MicroDim Controller.
6. Using the same technique that was used in #5, run a wire from the GND terminal on the MicroDim to system ground. The common (GND) wire is simply a signal wire used by the unit. It does not carry heavy currents during operation. Use a blue solderless ring terminal for this wire. Connect to GND terminal of device.
7. Again using the same technique that was used in #5, run wire from output CKT for the dimming circuit. Select and install a blue solderless ring terminal to the end of the wire and connect it to the CKT terminal on the MicroDim Controller.
8. With the MicroDim Controller inserted from the rear into the 9mm drilled hole and with the reference label placed over the threads on the MicroDim, install a washer and a nut to hold the MicroDim in place.
9. Install the knob using the 1/16" long handle key Allen wrench provided.

#### FUNCTIONAL TEST:

1. Turn the knob fully counter-clockwise to eliminate power to the system.
2. Slowly rotate the knob clockwise. The CKT1 will activate and with a continued clockwise rotation the lights will increase in intensity.
3. Full clockwise rotation applies the full voltage to the lights MicroDim circuit (CKT1).
4. Full counter-clockwise removes the voltage from the lights MicroDim circuit (CKT1).
5. CKT2 of the MicroDim will be at full voltage when there is an output on CKT1.
6. The light MicroDim circuit voltage is continuously variable from off to full on.

Wiring Diagram 9100-001-J MicroDim SWP

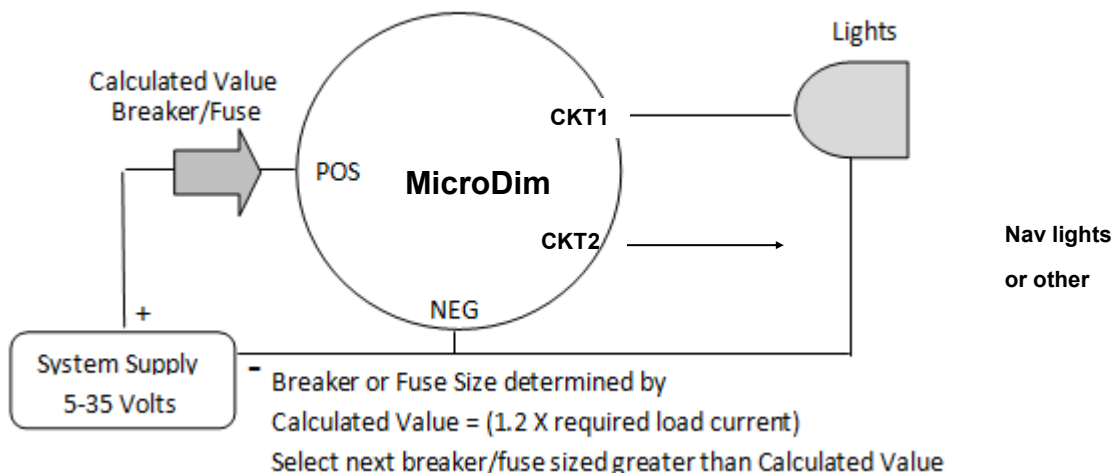

## —SPECIFICATIONS—

**Voltage Range:** 5 to 35VDC

**Max Current:** 7.5 A

**Controlled Output:** 0 to 5/35 VDC  
0 to 7.5A

**Capacity:**

- 38 Watts @ 5 VDC
- 90Watts @12 VDC
- 180 Watts @ 24 VDC
- 210 Watts @ 28 VDC

**Operating Temperature range:** -10°C to +70°C

**Internal Temperature Protect:** +85°C

**Storage Temperature:** -40°C to +100°C

**Maximum Internal Temperature:** @ 7.5A  
+5 °C above ambient.

**Enclosure Material:** PA-765B meets UL94 V2,  
V0, V5B, 5VA flame rating

**Approvals:** RTCA/DO-160G: RFE Qualified

Order P/N 9100-001-J Option SWP

**Potentiometer Rotation:** 300 Deg.

**Rotational Life:** 500K Turns

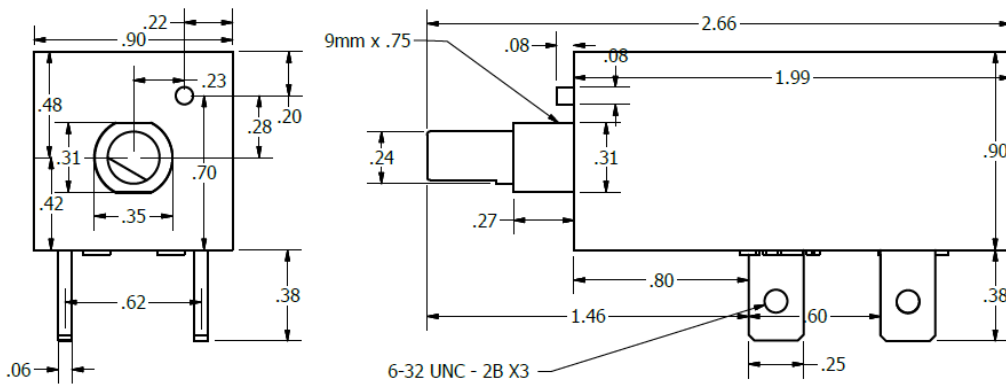

### ONE YEAR LIMITED WARRANTY

Seaton Engineering will repair or replace, at its expense and its option any device manufactured by Seaton Engineering which in normal use has proven to be defective in workmanship or material, provided that the customer returns the product prepaid to Seaton Engineering along with proof of purchase of the product within one year and provides Seaton Engineering with reasonable opportunity to verify the alleged defect by inspection. Seaton Engineering will not be responsible for any asserted defect which has resulted from misuse, abuse, or over stressing above the published specifications. Seaton Engineering will under no circumstances be liable for incidental or consequential damages resulting from the defective products; all other warranties, expressed or implied, whether of merchantability, fitness for purpose, or otherwise, are expressly disclaimed by Seaton Engineering.

**Seaton Engineering Corp.**

## Placards

Three placards are furnished with each MicroDim unit. They have a sticky back on them.

1. One with a matt-black background. The black background will appear as a matt finish placard on black panels. It is totally opaque and the panel color will not show through the placard.
2. One with a clear background. The clear background is intended to be used on panels that are a lighter color or when you want the panel color to show in the clear areas of the placard.
3. One clear overlay. One clear overlay is provided to put on top of the black or clear placard. This will change the appearance of the placard and give it a gloss look.

The clear overlay also provides a level of protection for the printed info on the placard. Use the bushing of the device to orient the placard to the hole, then touch it down when it is in the proper alignment. Youtube.com has many examples of using the “hinge” method of aligning and applying graphics.