

~1.5 inch dia

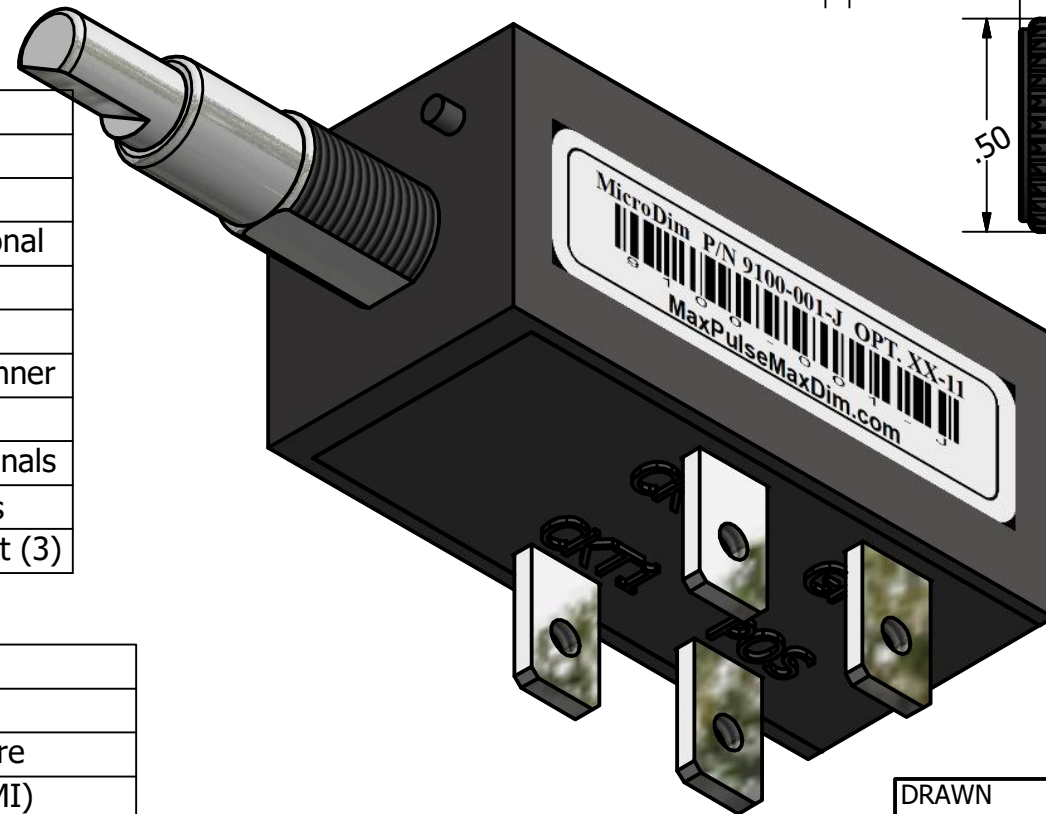

~1.5 inch dia

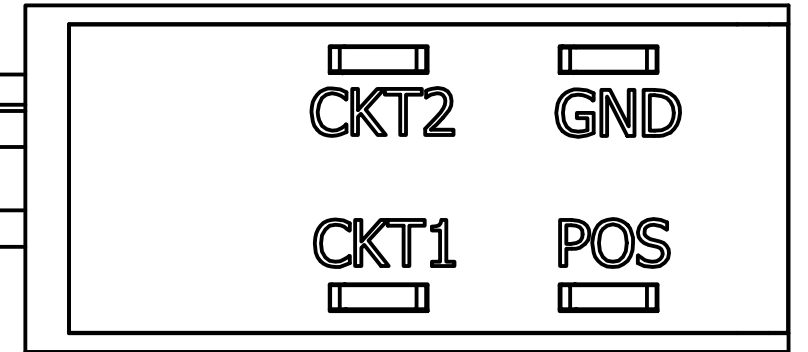
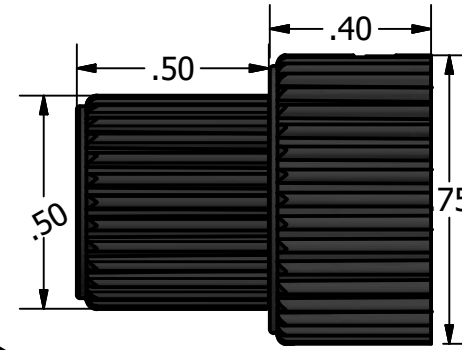
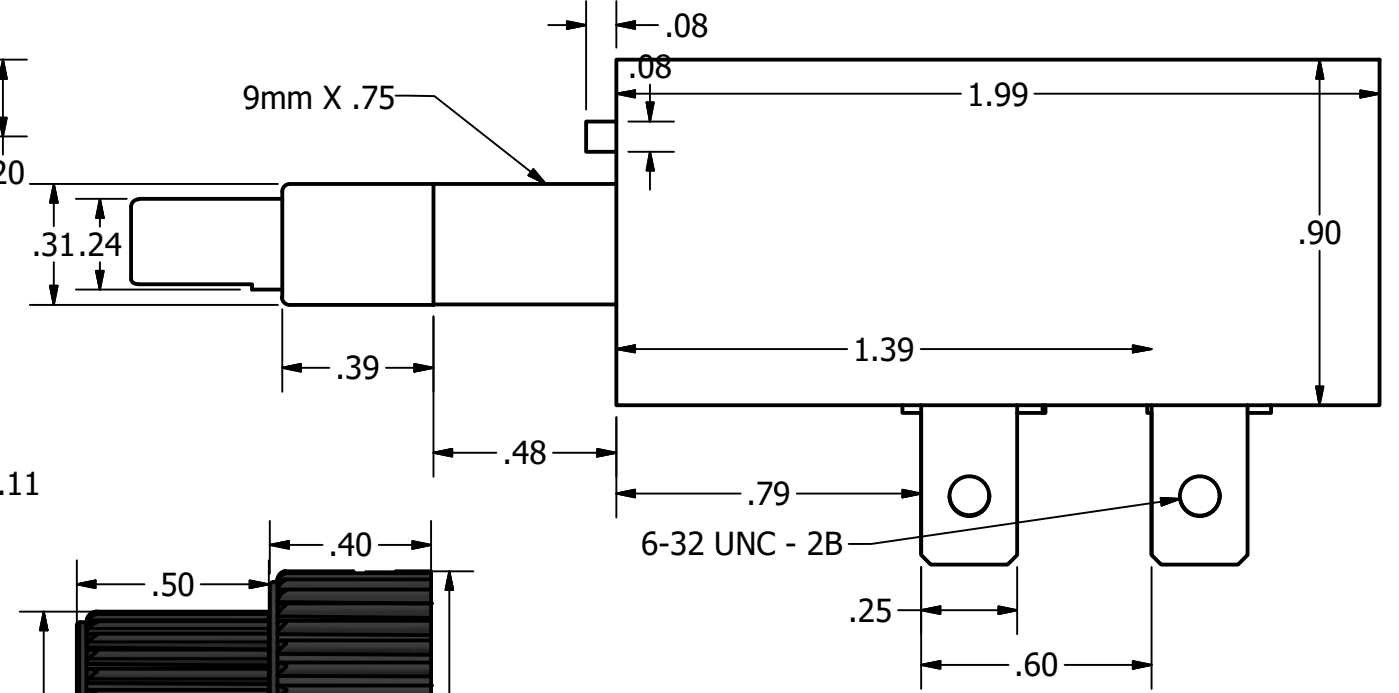
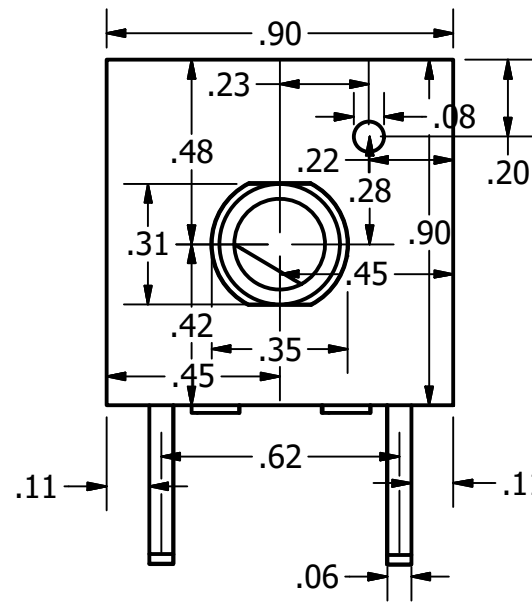

PARTS LIST

1	Dual MicroDim with ring lugs
1	Installation instructions optional
1	3M VHB double sided mounting tape optional
3	Placards black, clear + cover optional
1	Installation drill template optional
2	Knobs with set screws. large outer, small inner
3	Color coded terminals
4	6-32 screws (4), lock washers (4) for terminals
2	Allen Wrenches for Knob and Terminals
1	9mm X .75 washer (2), lock washer (3), nut (3)

SPECIFICATIONS

Part Number	9100-001-J
Option (XX)	Enter option here
DO-160G	SEC. 21:RFE (EMI)
Voltage Range	5 to 35 VDC
Maximum Current	10 A per Channel
Output Channels	2
Enclosure Material	PA-765B meets UL94 V-2, V-0 5VB, 5VA Flame Rating
Pot Rotation	300 Degree +/- 7%
Weight	1 ounce (28g)
Warranty	One Year Limited
Storage Temperature	-40C to +100C
Internal Temp	+25 C at 10 A

DIMENSIONAL TOLERANCES

Fractions	Decimals	Angles
+/- 1/32	.XX +/- .08	+/- 1 degree
	.XXX +/- .010	
	X +/- .1	

REVISION HISTORY

ZONE	REV	DESCRIPTION	DATE	APPROVED
All	A	Move to injection molding	11/4/2018	JB

DRAWN	9/17/2018
JB	
CHECKED	11/5/2018
JC	
QA	
MFG	11/4/2018
JB	
APPROVED	11/4/2018
JB	

Seaton Engineering
 TITLE: **Dual Channel MicroDim w/11mm Bushing**
 SIZE: **B** DWG NO: **9100-001-J-(XX)-11** REV: **A**
 SCALE: **2 : 1** SHEET **1** OF **1**