

Dual MaxDim Installation Instructions

P/N 9100-001-C & 9100-001-D

PARTS SUPPLIED 9100-001-C:

- 1ea Dual MaxDim Controller P/N 9100-001-C, including STC logbook copy.
- 1ea fully insulated red female crimp-on spade connector for 16-22 AWG wire.
- 3ea fully insulated blue female crimp-on spade connectors for 14-16 AWG wire.
- 1ea Placard
- 1ea installation template
- 1ea 1/16" long handle key Allen wrench
- 1ea dual knob set

PARTS SUPPLIED 9100-001-D:

- 1ea Dual MaxDim Controller P/N 9100-001-D, including STC logbook copy.
- 1ea fully insulated red female #6 crimp-on ring terminal for 16-22 AWG wire.
- 3ea fully insulated blue female #6 crimp-on ring terminals for 14-16 AWG wire.
- 4ea 6-32 X 1/4" button head socket SS screws including #6 SS internal lock washer.
- 1ea 1/16" long handle key Allen wrench
- 1ea 5/64" long handle key Allen wrench
- 1ea placard
- 1ea installation template
- 1ea dual knob set

NEW INSTALLATION:

1. Locate a convenient place for the Dual MaxDim Controller. Using the template provided, drill two holes. Drill the first one (3/8") at the location where the center of the dimmer is desired. Drill the second (anti-rotation) hole (11/64"), offset to the left from the first 3/8" hole.
2. Determine the current that the circuit will be required to carry.
3. Test position the Dual MaxDim Controller and determine the lengths of the wires required.
4. Remove the Dual MaxDim Control and proceed with the installation. From the **WIRE SIZE-CURRENT CAPACITY TABLE**, select the wire size required. If the installation is in an aircraft, use only MIL-W-16878E/4 Type E, Teflon insulated, Silver-Plated Copper Wire, or equivalent.
5. Find the location of the power source.

9100-001-C WIRING: (PUSH ON SPADE CONNECTORS)

1. Install a "**CALCUATED**" breaker for the 9100-001-C Dual MaxDim Controller power source. **The installer should insure that each circuit is properly protected with a circuit breaker or breakers.**
2. Run the supply source wire from the breaker to the MaxDim controller positive (POS) terminal. Then select and crimp a blue female spade connector to the end of the supply source wire. Push the female connector onto the POS male terminal on the MaxDim Controller.
3. Using the same technique that was used with the supply source wire, run a wire from the (GND) terminal on the MaxDim to system ground. The common (GND) wire is simply a signal wire used by the unit and does not carry heavy currents during operation. Use a red female crimp-on connector for this wire. Push this connector onto the male GND terminal of the MaxDim.

Covers Dual MaxDim 9100-001-C & D

9100-001-D WIRING: (SCREW ON CONNECTORS)

The installation and wiring of the 9100-001-D Dual MaxDim Controller is the same as the wiring instructions for the 9100-001-C except for the connectors attached to the wires. The screw on connections use ring terminals instead of push on connectors. Perform the same operations found in the 9100-001-C wiring instructions except crimp ring terminals to the ends of the wires instead of the spade connectors.

1. Install a "**CALCULATED**" breaker for the 9100-001-D Dual MaxDim Controller power source. **The installer should insure that each circuit is properly protected with a circuit breaker or breakers.**
2. Run the supply source wire from the breaker to the MaxDim Controller positive (POS) terminal. Select and crimp a blue female ring terminal to the end of the supply source wire. Using the button head screw and the lock washer, connect the ring terminal to the POS terminal on the MaxDim Controller.
3. Using the same technique that was used with the supply source wire, run a wire from the (GND) terminal on the MaxDim to system ground. The common (GND) wire is simply a signal wire used by the unit and does not carry heavy currents during operation. Use a red female ring terminal for this wire. Using the button head screw and the lock washer, connect the ring lug to the GND terminal of the MaxDim Controller.
4. Again, using the same technique that was used with the source wire, run a wire from the (CKT #1) for the CKT #1 dimming circuit. Select and install a blue female ring terminal to the end of the CKT #1 wire. Using the button head screw and the lock washer, connect the ring terminal to terminal CKT #1 on the Dual MaxDim Controller.
5. Again, using the same technique that was used with the source wire, run a wire from output CKT #2 for the CKT #2 dimming circuit. Select and install a blue female terminal. Using the buttonhead screw and the lock washer, connect the ring terminal to terminal CKT #2 on the Dual MaxDim Controller.
6. With the Dual MaxDim Control inserted from the rear into the 3/8" drilled hole and with the placard placed over the threads on the Dual MaxDim Controller, install a washer and a nut to hold the Dual MaxDim Controller in place. Before tightening the nut, insure that the anti-rotation plastic pin is seated in the 0.170" (11/64") hole and the placard is vertically aligned.
7. Install the dual knob set using the provided 1/16" hex wrench.

FUNCTIONAL TEST: BOTH 9100-001-C & D

Turn the dual knobs fully counter-clockwise to eliminate power to the system.

1. Slowly rotate the each knob clockwise. The lamp dimmer circuits will activate and with a continued clockwise rotation the lamps will increase in intensity.
2. Full clockwise rotation of each knob independently applies the voltage to the circuit wired to it.
3. Full counter-clockwise removes the voltage from the lamp dimmer circuit.
4. The Dual MaxDim circuit voltages are continuously variable from off to full on.

DETERMINING THE BREAKER SIZE:

1. Determine total current required by the loads and multiply by 1.2. Select the next higher rated breaker to use with your Dual MaxDim.

**General Engineering Data Regarding Wire Sizes and Current Capacities Capacity Data
WIRE AND CABLE DERATING CRITERIA FROM MIL-STD-975**

AWG	Diameter	Diameter	Ohms Per	Ohms Per	Maximum	AWG	Derated Current	
Gauge	Inches	mm	1000 Ft	km	Ampere	Gauge	Single	Bundled
14	0.0641	1.6281	2.525	8.282	32	14	19.0	8.5
15	0.0571	1.4503	3.184	10.4435	28	15	16.6	7.4
16	0.0508	1.2903	4.016	13.1725	22	16	13.0	6.5
17	0.0453	1.1506	5.064	16.6099	19	17	11.2	5.6
18	0.0403	1.0236	6.385	20.9428	16	18	9.2	5.0
19	0.0359	0.9119	8.051	26.4073	14	19	8.1	4.4
20	0.032	0.8128	10.15	33.292	11	20	6.5	3.7
21	0.0285	0.7239	12.8	41.984	9	21	5.3	3.0
22	0.0254	0.6452	16.14	52.9392	7	22	4.5	2.5

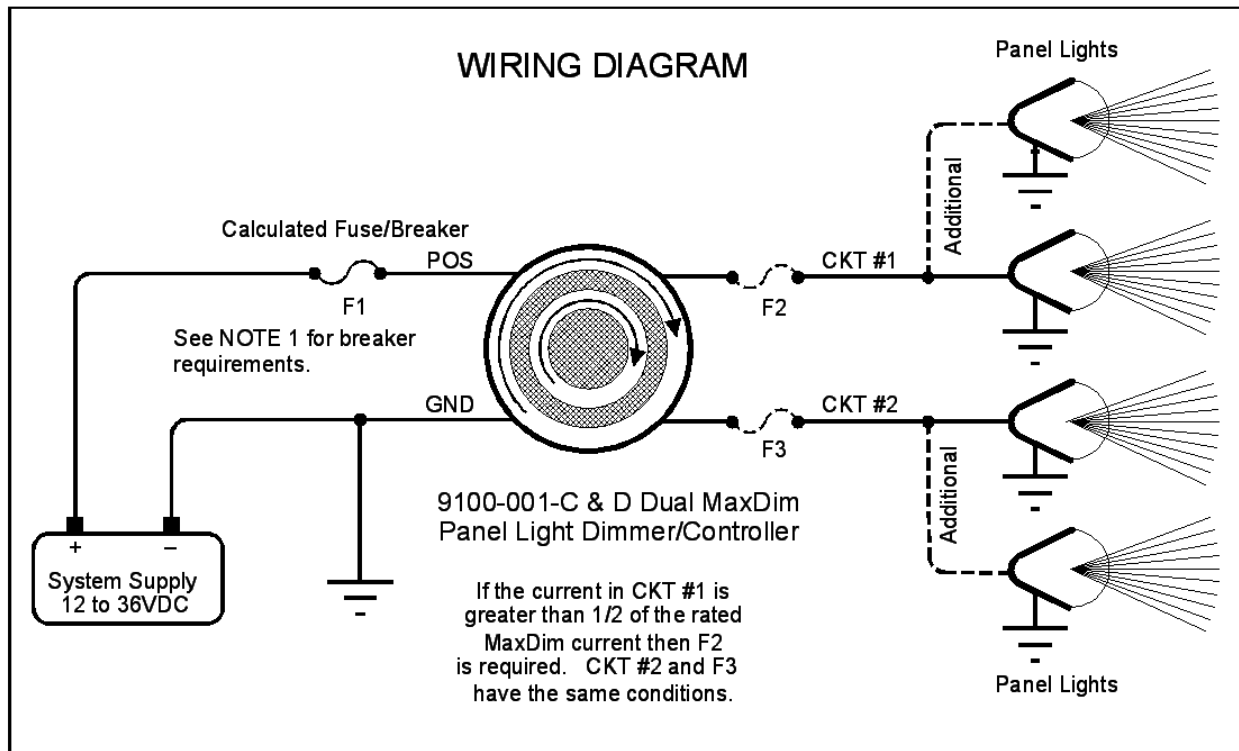

—SPECIFICATIONS—

Voltage Range: 12 to 35VDC

Controlled Output: 0 to 12/35 VDC

9100-001-C: Spade Terminal

Max Current: 10A

Capacity:

- 120 Watts @ 12VDC
- 240 Watts @ 24VDC
- 350 Watts @ 35VDC

9100-001-D: Ring Terminal

Max Current: 10A

Capacity:

- 120 Watts @ 12VDC
- 240 Watts @ 24VDC
- 350 Watts @ 35VDC

Operating Temperature range: -30°C to +65°C

Internal Temperature Protect: +85°C

Storage Temperature: -40°C to +100°C

Maximum Internal Temperature: @10A X 2
+15 °C above ambient

Enclosure Material: Bayer FR 110 Resin

Meets UL 94 Flame Rating: V-2 (0.03in) V-0
(0.059in) 5VB (0.098in) 5VA (0.13in)

Approvals: FAA PMA STC SA01800SE

RTCA/DO-160E Tested/Qualified EMI

Potentiometers Rotation: 300 Deg.

Rotational Life: 500K Turns

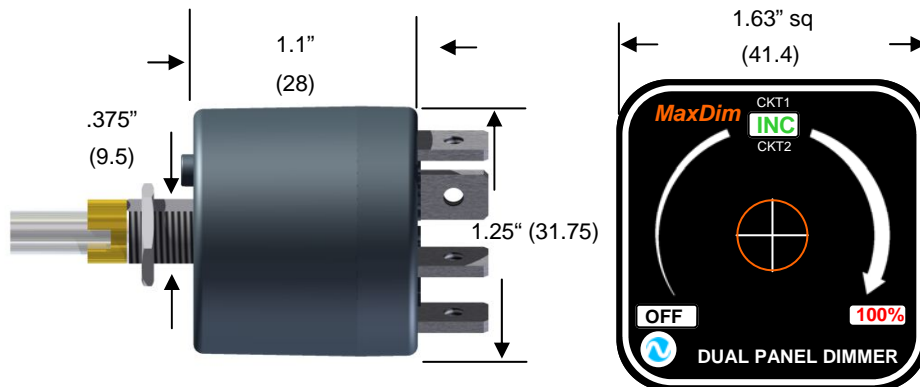

Seaton Engineering Corp

Loon Lake, WA 99148

Covers Dual MaxDim 9100-001-C & D

CAUTION

Many EFIS, GPS, and other equipment with screens have their own internal dimmer circuitry and only the steam gauge instruments and panel lights are controlled by an independent dimmer. However, the installing technician and the owner must perform a post installation check for proper function and verification of compatibility with any existing equipment that might appear on these aircraft. With the possibility that there might be Electronic Flight Instrument Systems (EFIS) tied into the existing dimmer circuitry, the FAA has advised that the installing Technician and owner verify that they cannot dim any (EFIS) all the way to zero, so there is no danger of failure of this simple dimmer causing all the (EFIS) displays/instruments to be black. If this incompatibility exists the (EFIS) must be removed from the dimming circuit.

FAA REQUIREMENTS

Amend the weight and balance records and make the necessary log book entry. Complete an FAA form 337 showing the installation of this equipment in accordance with the STC instruction and submit one copy to the FAA and one copy to the aircraft owner. File all data and a copy of the STC with the aircraft records.

INSTRUCTIONS FOR CONTINUED AIRWORTHINESS

The Airworthiness Limitations section is FAA approved and specifies maintenance required under Part 43.16 and 91.403 of the FAR's unless and alternative program has been FAA approved. **Airworthiness Limitation:** MaxDim P/N 9100-001-C & D Light Dimming Controllers, manufactured by Seaton Engineering Corporation have no repairable parts and if a failure occurs, the part must be replaced in its entirety.

ONE YEAR LIMITED WARRANTY

SEC will repair or replace, at its expense and at its option any device manufactured by SEC which in the normal use has proven to be defective in workmanship or material, provided that the customer returns the product prepaid to SEC along with proof of purchase of the product within one year and provides SEC with reasonable opportunity to verify the alleged defect by inspection. SEC will not be responsible for any asserted defect which has resulted from misuse, abuse or over stressing above the published specifications. SEC will under no circumstances be liable for incidental or consequential damages resulting from the defective product. This warranty is SEC's sole warranty and sets forth the customer's exclusive remedy, with respect to defective products; all other warranties, express or implied, whether of merchantability, fitness for purpose, or otherwise, are expressly disclaimed by SEC.

Seaton Engineering Corp.

United States of America
Department of Transportation Federal Aviation Administration
Supplemental Type Certificate

Number SA01800SE

This certificate, issued to:

**Seaton Engineering Corp.
40145 Sunset Drive
Loon Lake, WA 99148**

certifies that the change in the type design for the following product with the limitations and conditions therefore as specified hereon meets the airworthiness requirements of Part 23 of the Code of Federal Regulations.

Original Product-Type Certificate Number:

*See attached Approved Model List (AML)

Make:

No. SA01800SE for list of approved aircraft

Model:

models and applicable airworthiness regulations

Description of the Type Design Change: Fabrication and installation of new or replacement of existing instrument panel lights dimmer control. Installation in accordance with Seaton Engineering Corp. FAA approved Master Drawing document 9750-002, dated May 10, 2007, or later FAA approved revision.

Limitations and Conditions: Approval of this change in type design applies to only the aircraft listed on the approved model list. This approval should not be extended to models on which other previously approved modifications are incorporated unless it is determined by the installer that the relationship between this change and any of those other previously approved modifications, including changes in type design, will introduce no adverse effect upon the airworthiness of that aircraft. A copy of this certificate must be maintained as part of the permanent records of the modified aircraft.

If the holder agrees to permit another person to use this certificate to alter the product, the holder shall give the other person written evidence of that permission.

This certificate and the supporting data which is the basis for approval shall remain in effect until surrendered, suspended, revoked, or a termination date is otherwise established by the Administrator of the Federal Aviation Administration.

Date of application: November 3, 2006

Date reissued: December 1, 2011; July 16, 2019

Date of issuance: October 30, 2007

Date amended:



By direction of the Administrator

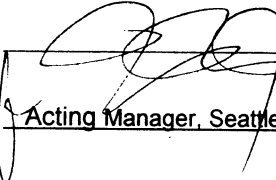

(Signature)
Acting Manager, Seattle ACO Branch

(Title)

Any alteration of this certificate is punishable by a fine of not exceeding \$1,000, or imprisonment not exceeding 3 years, or both. This certificate may be transferred or made available to third persons by licensing agreements in accordance with 14 CFR 21.47. Possession of this Supplemental Type Certificate (STC) document by persons other than the STC holder does not constitute rights to the design data nor to alter an aircraft, aircraft engine, or propeller. The STC's supporting documentation (drawings, instructions, specifications, flight manual supplements, etc.) is the property of the STC holder. An STC holder who allows a person to use the STC to alter an aircraft, aircraft engine, or propeller must provide that person with written permission acceptable to the FAA. (Ref. 14 CFR 21.120). This certificate may be transferred in accordance with FAR 21.47.



To whom it may concern:

Please use this letter as evidence of permission granted by the holder of STC SA01800SE, to the user, to install Seaton Engineering's MaxDim or MiniDim Lamp Intensity Controller, model 9100-001-A/B/C/D/E/F/G or H in an aircraft included on the Approved Model List referenced by STC SA01800SE.

A handwritten signature in black ink, appearing to read "Jeff Christensen", with a horizontal line extending to the right.

Jeff Christensen
President/CEO
Seaton Engineering Corporation
40145 Sunset Drive
Loon Lake, WA. 99148