

MicroDim Single P/N 9100-001-I

Installation and Operating Instructions

PARTS SUPPLIED 9100-001-I :

- 1ea MicroDim Control P/N 9100-001-I, installation manual
- 3ea fully insulated blue female #6 crimp-on ring terminals for 14-16 AWG wire
- 3ea 6-32 X 1/4" button head socket SS screws including #6 SS internal lock washer
- 1ea 1/16" long handle key Allen wrench
- 1ea 5/64" long handle key Allen wrench
- 2ea reference sticky-back panel label, black background and clear
- 1ea knob, drill guide for bushing/anti-rotation pin, mounting hardware

CAUTION - REVERSE WIRING OF POWER TO DEVICE WILL DAMAGE IT

NEW INSTALLATION: CHECK PHYSICAL MOUNTING INSTRUCTIONS ON PAGE 4

1. Locate a convenient place for the MicroDim Controller. Drill a 9mm hole at the location where the center of the MicroDim is desired. Drill 2mm anti-rotation pin hole if required.
2. Determine the current that the circuit will be required to carry.
3. Test position of MicroDim Controller and determine if any additional wire is required.
4. Remove the MicroDim Control and proceed with the installation. From a **WIRE SIZE-CURRENT CAPACITY TABLE**, select the wire size required. If the installation is in an aircraft, use only MIL-W-16878E/4 Type E, Teflon insulated, Silver-Plated Copper Wire or equivalent.
5. Find the location of the power source.
6. Install a breaker of "Calculated Size", see wiring diagram for sizing.
7. Run a wire from the breaker to the MicroDim controller positive (POS) terminal, then select and crimp a blue female solderless ring terminal on the end of the wire. Attach the ring terminal to the positive connector on the MicroDim controller using a washer and a SS screw .
8. Using the same technique that was used in section #7, run a wire from the GND ring terminal on the MicroDim to system ground. The common (GND) Wire is simply a signal wire used by the unit. It does not carry heavy currents during operation. Use a blue female solderless ring terminal for this wire.
9. Again using the same technique that was used in section #7, run a wire from the output CKT on the dimming circuit. Select and crimp a blue ring terminal to the end of the wire. Attach the ring terminal to the MicroDim controller using a washer and a button head socket SS screw.
10. Having installed the label over the 9mm drilled hole using the label installation instructions, insert the MicroDim from the rear into the drilled hole and install a washer and the nut to hold the MicroDim in place and tighten the nut.
11. Install the knob using the long handle key Allen wrench provided.

EXISTING/REPLACEMENT INSTALLATION:

1. Locate a convenient place for the MicroDim Controller. Drill a 9mm hole at the location where the center of the MicroDim is desired. Determine the positive supply, MicroDim circuit, and negative ground wiring.

2. Test position the MicroDim Controller and determine if any additional wire is required for the install.
3. Insure that a breaker for the MicroDim Controller power source is installed in series with power source and sized to "Calculated Value" as defined on the wiring diagram.
4. Remove the MicroDim Control and proceed with the installation. From the wire size-current capacity table, select the wire size if additional wire is required. If the installation is in an aircraft, use only MIL-W-16878E/4 Type E, Teflon insulated, or equivalent silver-plated copper wire.
5. Run a wire from the breaker to the MicroDim Controller positive (POS) terminal, then select and install a blue female solderless ring terminal on the end of the wire. Attach this to the POS connector on the MicroDim controller.
6. Using the same technique that was used in #5, run a wire from the GND terminal on the MicroDim to system ground. The common (GND) wire is simply a signal wire used by the unit. It does not carry heavy currents during operation. Use a blue solderless ring terminal for this wire. Connect to GND connector of device.
7. Again using the same technique that was used in #5, run wire from output CKT for the dimming circuit. Select and install a blue solderless ring terminal on the end of the wire and connect it to the connector on the MaxDim Controller.
8. With the MicroDim Controller inserted from the rear into the 9mm drilled hole and with the reference label placed over the threads on the MaxDim Micro Controller, install a washer and a nut to hold the MicroDim Control in place.
9. Install the knob using the 1/16" long handle key Allen wrench provided.

FUNCTIONAL TEST:

1. Turn the knob fully counter-clockwise to eliminate power to the system.
2. Slowly rotate the knob clockwise. The lamp MicroDim circuit will activate and with a continued clockwise rotation the lamps will increase in intensity.
3. Full clockwise rotation applies the full voltage to the lamp MicroDim circuit.
4. Full counterclockwise removes the voltage from the lamp MicroDim circuit.
5. The lamp MicroDim circuit voltage is continuously variable from off to full on.

Wiring Diagram 9100-001-I MicroDim

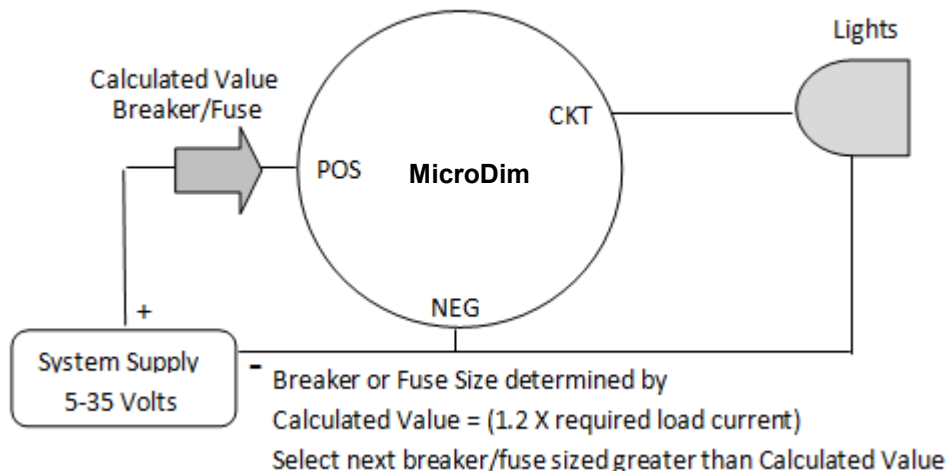

—SPECIFICATIONS—

Voltage Range: 5 to 35VDC

Max Current: 10A

Controlled Output: 0 to 5/35VDC
0 to 10A

Capacity:

- 50 Watts @ 5VDC
- 120 Watts @ 12VDC
- 240 Watts @ 24VDC
- 280 Watts @ 28VDC

Potentiometer Rotation: 300 Deg.

Rotational Life: 500K Turns

Operating Temperature range: -10°C to +70°C

Internal Temperature Protect: +85°C

Storage Temperature: -40°C to +100°C

Maximum Internal Temperature: @ 10A
+5° C above Ambient.

Enclosure Material: PA-765B, meets UL94 V2,
V0, V5B, 5VA flame rating

Approvals: RTCA/DO-160G: RFE Qualified

Order P/N 9100-001-I Option x-xx

Available in 6mm or 11mm exposed bushing
6mm shown below

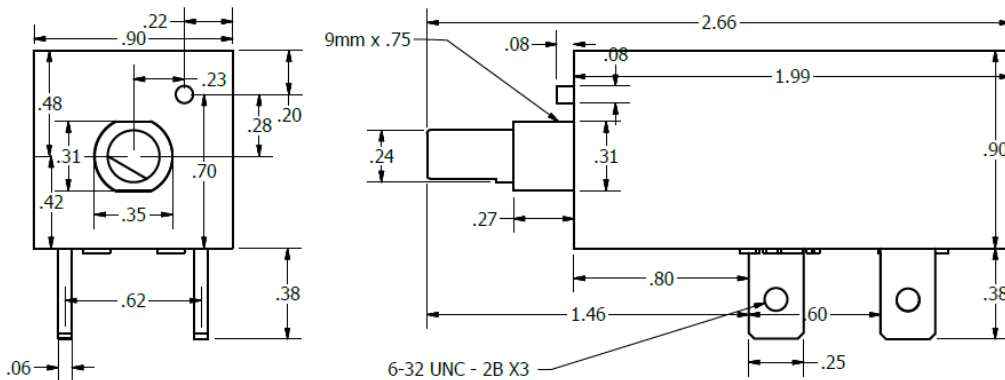

ONE YEAR LIMITED WARRANTY

Seaton Engineering will repair or replace, at its expense and its option any device manufactured by Seaton Engineering which in the normal use has proven to be defective in workmanship or material, provided that the customer returns the product prepaid to Seaton Engineering along with proof of purchase of the product within one year and provides Seaton Engineering with reasonable opportunity to verify the alleged defect by inspection. Seaton Engineering will not be responsible for any asserted defect which has resulted from misuse, abuse or over stressing above the published specifications. Seaton Engineering will under no circumstances be liable for incidental or consequential damages resulting from the defective products; all other warranties, expressed or implied, whether of merchantability, fitness for purpose, or otherwise, are expressly disclaimed by Seaton Engineering.

Seaton Engineering Corp.

Placards

Three placards are furnished with each MicroDim unit. They have a sticky back on them.

1. One with a matt black background. The black background will appear as a matt finish placard on black panels. It is totally opaque and the panel color will not show through the placard.
2. One with a clear background. The clear background is intended to be used on panels that are a lighter color or when you want the panel color to show in the clear areas of the placard.
3. One clear overlay. One clear overlay is provided to put on top of the black or clear placard. This will change the appearance of the placard and give it a gloss look.

The clear overlay also provides a level of protection for the printed info on the placard. Use the bushing of the device to orient the placard to the hole, then touch it down when it is in the proper alignment. Youtube.com has many examples of using the “hinge” method of aligning and applying graphics.

Physical Mounting Instructions

The MicroDim units with 11mm exposed bushings come with three inside star washers, three 9mm nuts and two washers. Two of the nuts/washers/star washers are for “double nutting” the device with the plastic not contacting the mounting surface. The unit will come with another inside 9mm star washer and nut that is tightened down to the plastic. This nut and star washer should not be removed if the plastic is not to be contacting the mounting surface and is suspended on the bushing.

This will provide a solid assembly when the dimmer is suspended on the bushing alone.

If need be, the nut securing the bushing to the plastic can be removed if the installation requires the full length bushing and the plastic is mounted solid against the mounting surface. Care should be taken not to rotate any dimmer plastic with force against a solid mounted bushing as it is possible to generate enough torque to damage the internal components of the dimmer.